

NO	PART NAME	PART#	REQ'D	MATERIAL
1	ID PLATE 3" X 3/4"	A15152	.5	ALUMINUM
2	DRIVE SCREW TYPE U #2 X 1/8"	DR218	2	18-8 SS
3	SURGE PROTECTOR	HSSPRD33	1	SALCO PE
4	QUICK INSPECT SAFETY VENT	QI261BSA	1	BLACK NORYL
5	QI RETAINER GASKET	QI261G12	1	BLACK VITON® GF-600S
6	QI RUPTURE DISK GASKET	QI261RDG12	1	BLACK VITON® GF-600S
7	RUPTURE DISC (SOLD SEPARATELY)			

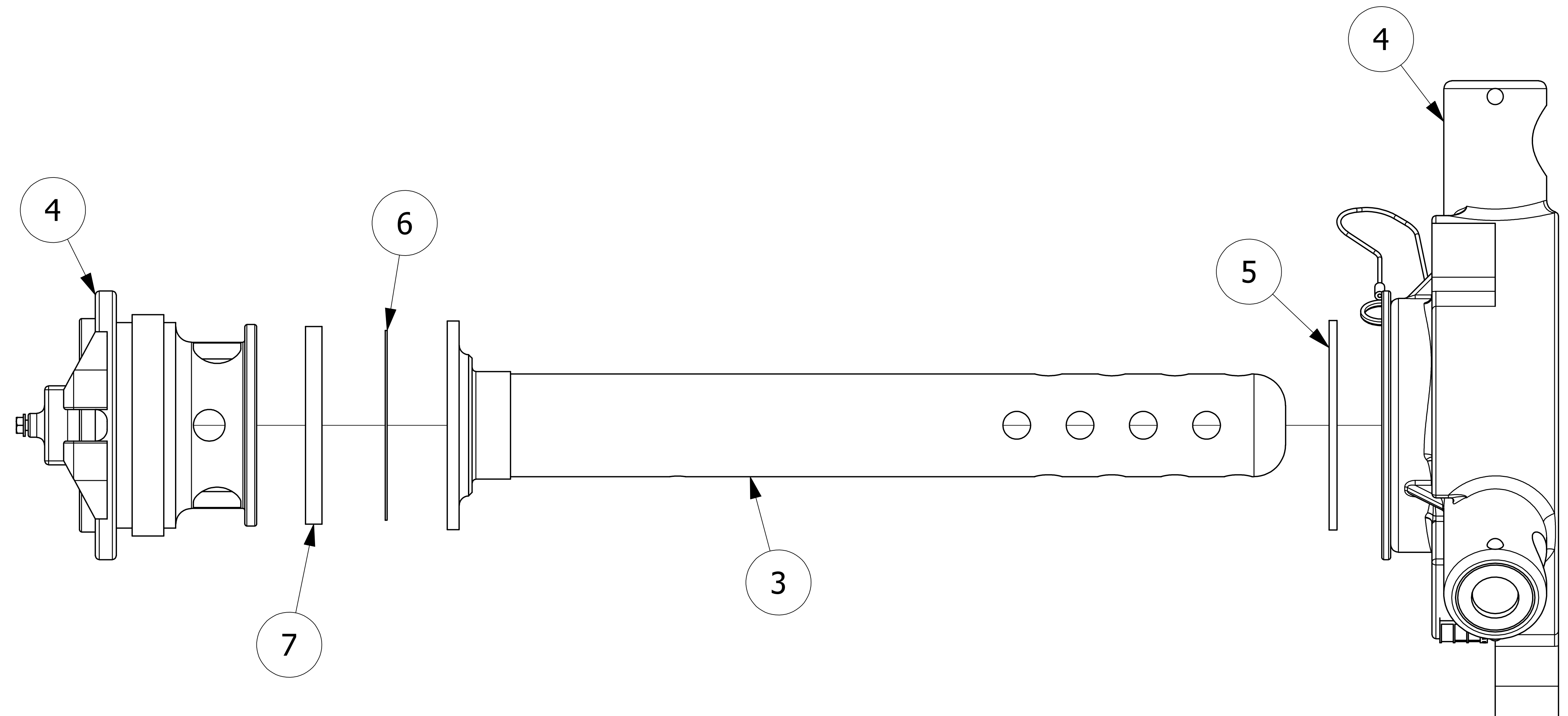
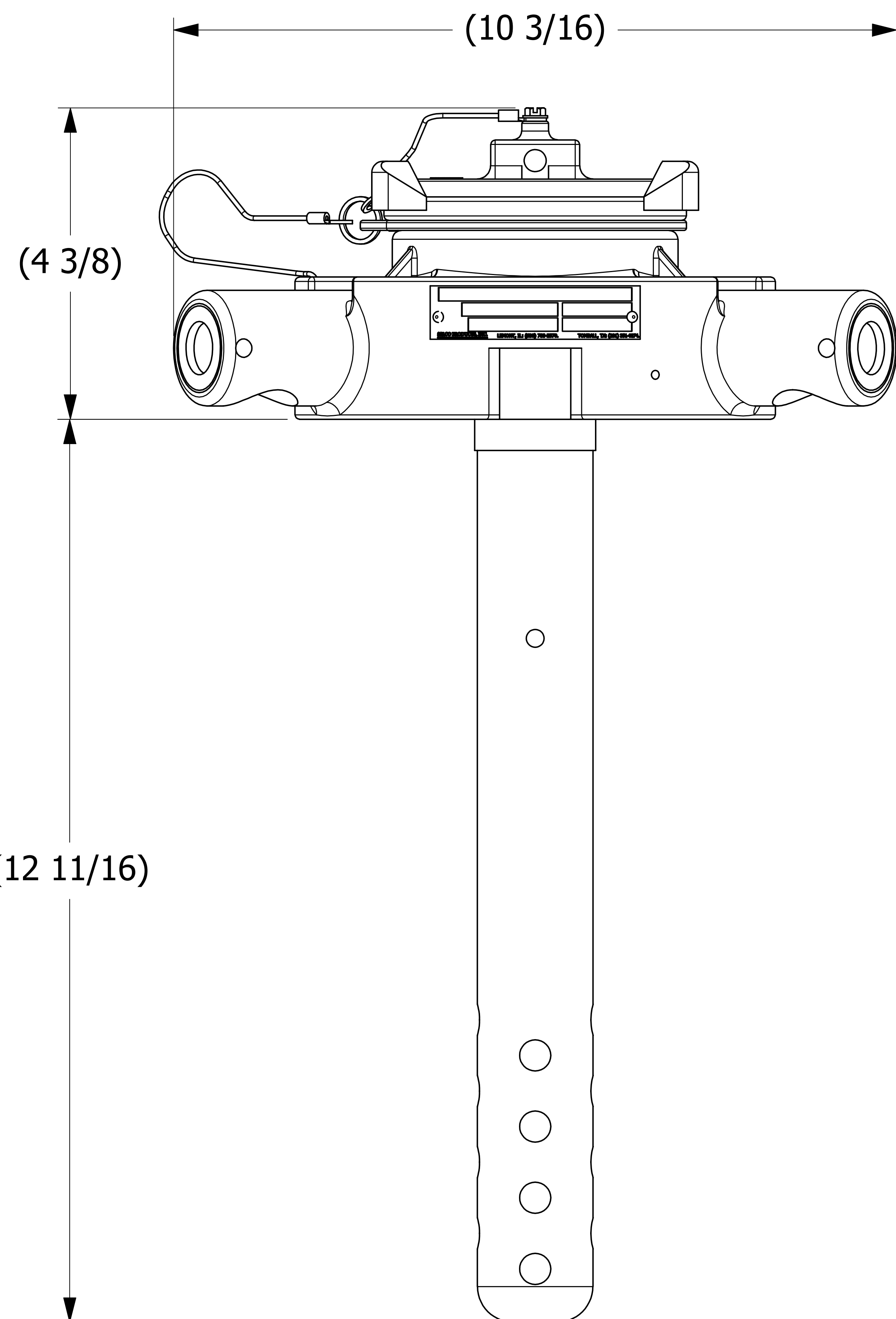
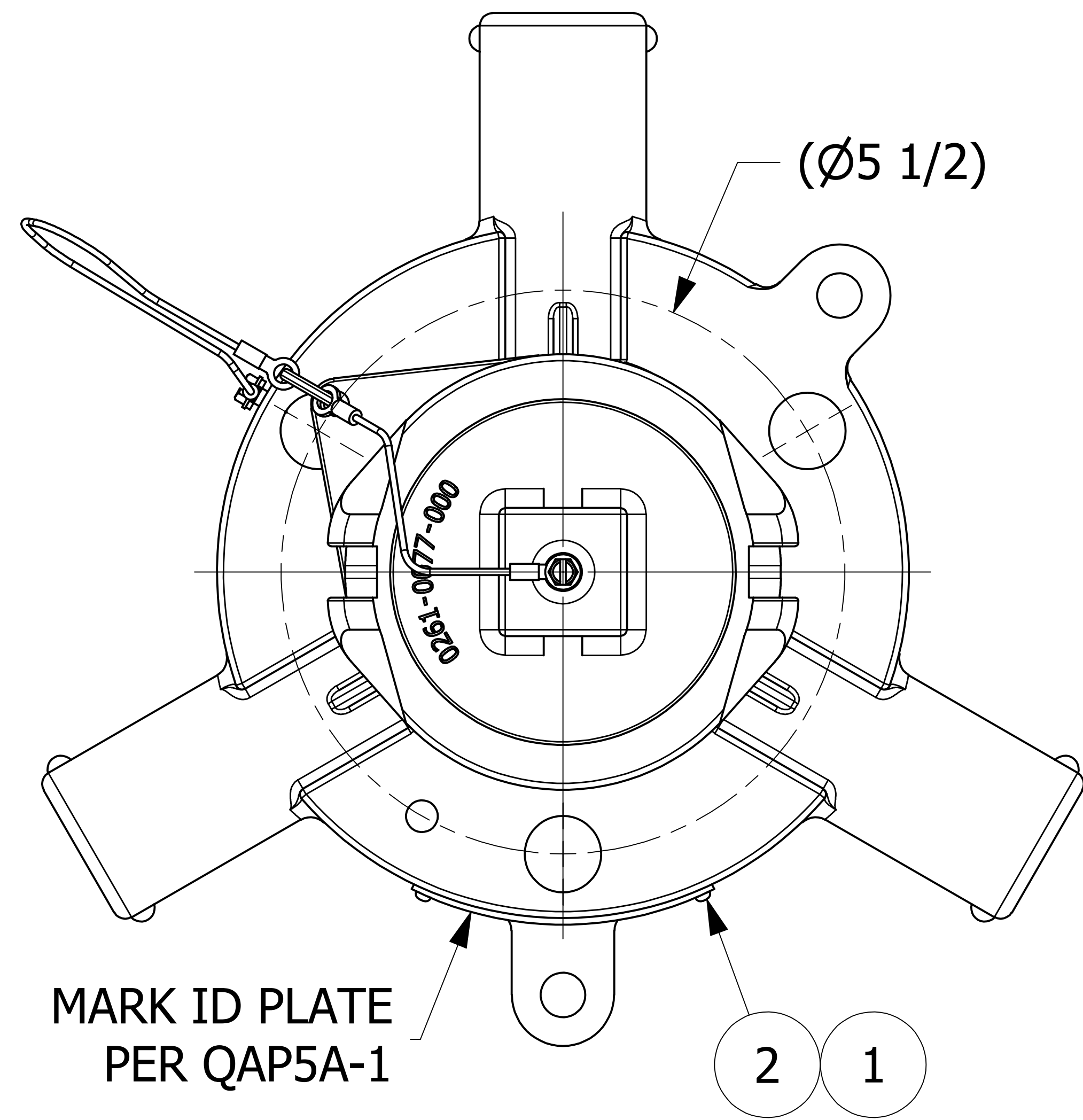

- NOTES:
1. CUSTOMERS RESPONSIBILITY FOR COMPATIBILITY OF COMMODITY.
  2. AAR APPROVAL # PRD-162102.
  3. THIS UNIT IS FOR RUBBER LINED FLANGES ONLY.
  4. SEE DOCUMENT QAP5A-1 FOR MARKING PROCEDURE.
  5. FASTEN ID PLATE WITH DRIVE SCREWS.

C	JG	2-7-17	AAR APPROVAL # WAS SRD-063000
B	TAK	9-4-13	ADDED A15152, DR218 & QAP5A-1 NOTE
A	PJG	5-8-08	NEW PART ADDED TO SYSTEM
REV	BY	DATE	DESCRIPTION

UNLESS OTHERWISE SPECIFIED DIMENSIONAL TOLERANCES FRACTIONAL: ±1/16 X.XX: ±.03 X.XXX: ±.015 ANGULAR: ±1° DEBURR ALL SHARP EDGES. ALL MACHINED SURFACES TO HAVE A 125 RMS FINISH UNLESS NOTED OTHERWISE. THIRD ANGLE PROJECTION	DRAWN BY:	PJG
	CHECKED BY:	WRB
	PROTOTYPE BY:	PJG
	PROTOTYPE DATE:	1/11/2008
	APPROVED FOR PRODUCTION BY:	PJG
PRODUCTION DATE:	1/11/2008	

**SALCO PRODUCTS, INC.**

**QUICK INSPECT SAFETY VENT**

MATERIAL: **SEE BOM**

PROJECT #: **WAG0503** SHEET #: **1 OF 1** SCALE: **1:1**

DRAWING #: **E24616** PART #: **QI261HSP12LA**