

NO	PART NAME	PART#	REQ'D	MATERIAL
1	ID PLATE 3" X 3/4"	A15152	.5	ALUMINUM
2	DRIVE SCREW TYPE U #2 X 1/8"	DR218	2	18-8 SS
3	QUICK INSPECT FLANGE GASKET	FG550V	1	BLACK VITON A
4	QUICK INSPECT SAFETY VENT	QI261BSA	1	BLACK NORYL
5	QI RETAINER GASKET	QI261G6	1	BLACK VITON A
6	RUPTURE DISC (SOLD SEPARATELY)			

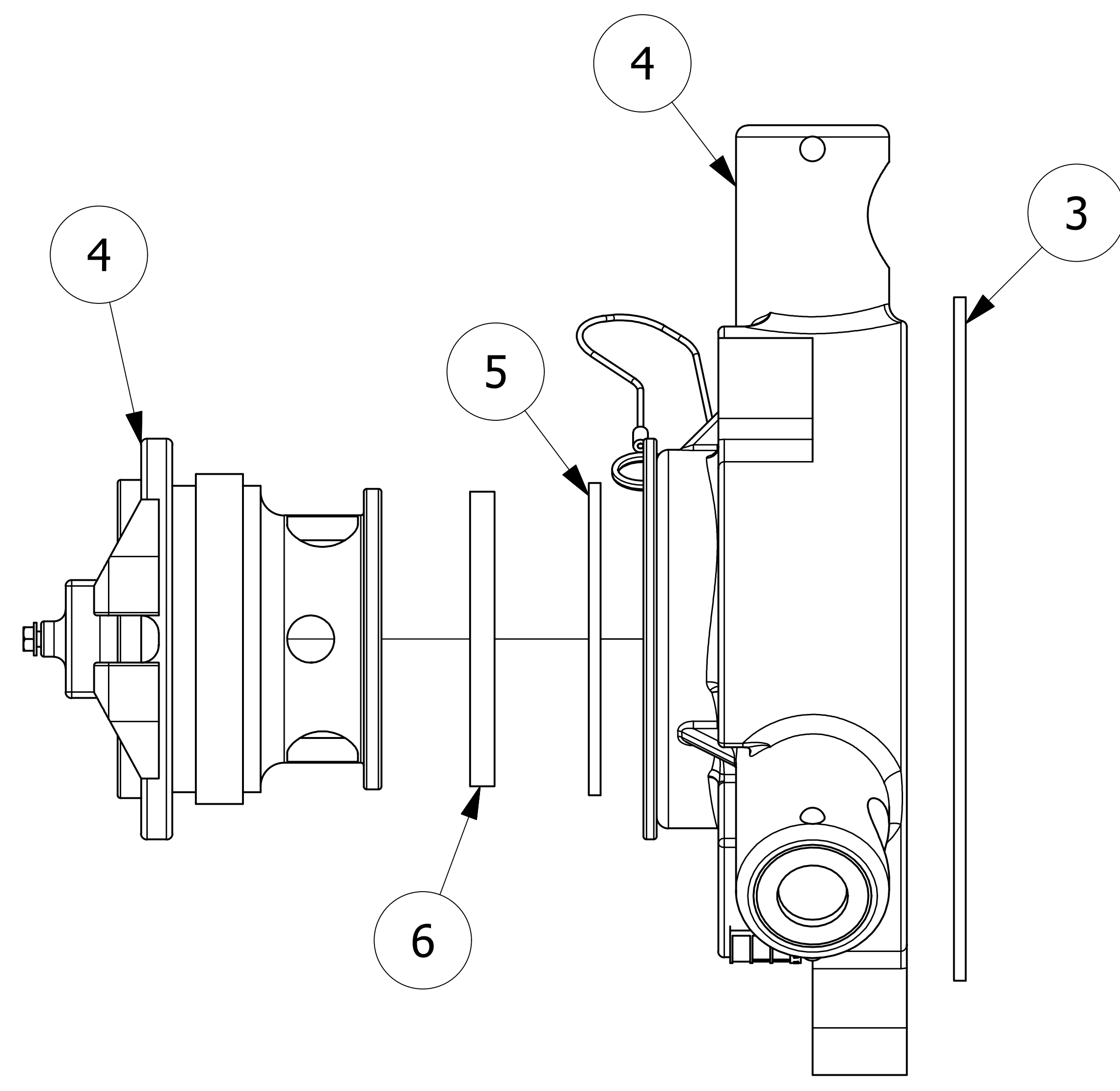
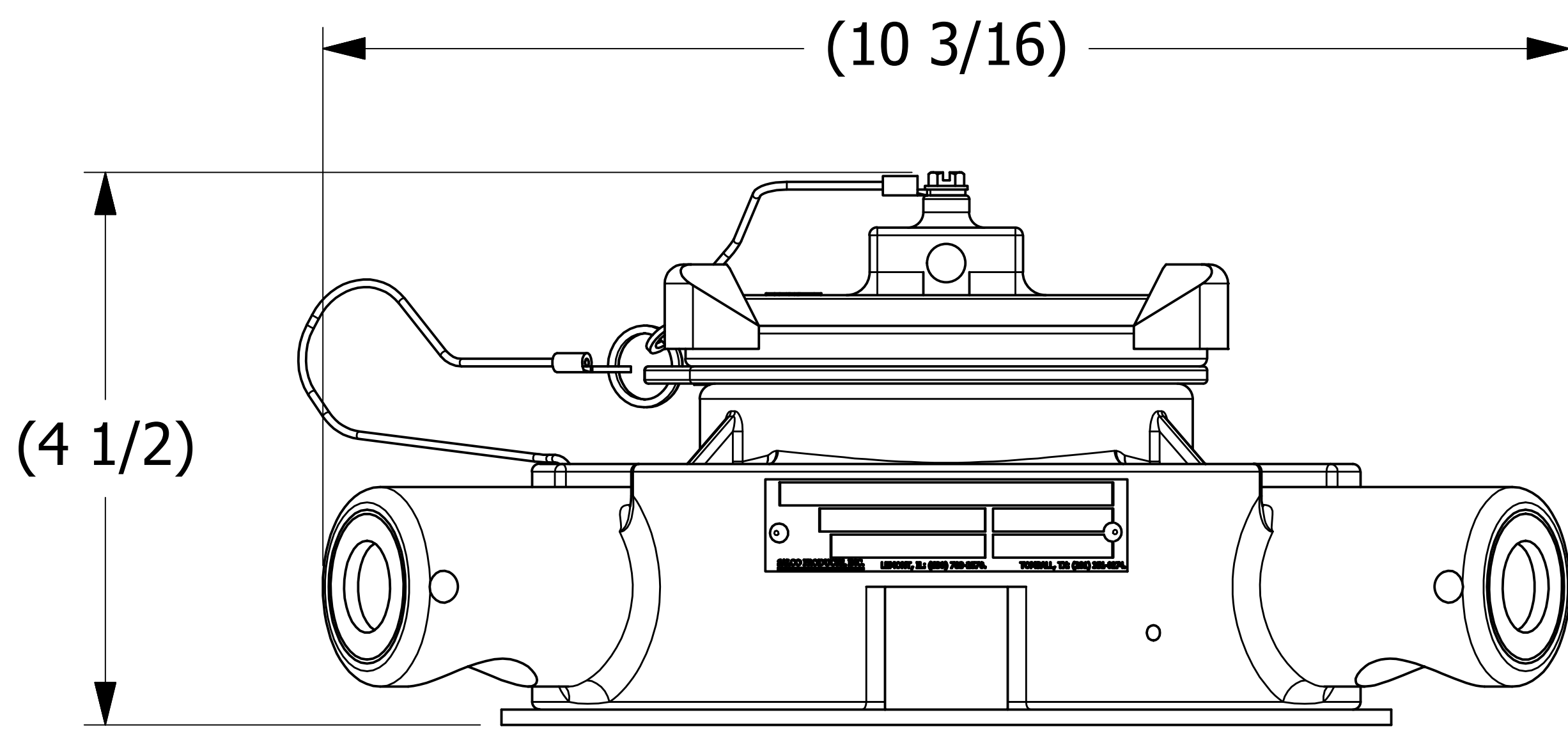
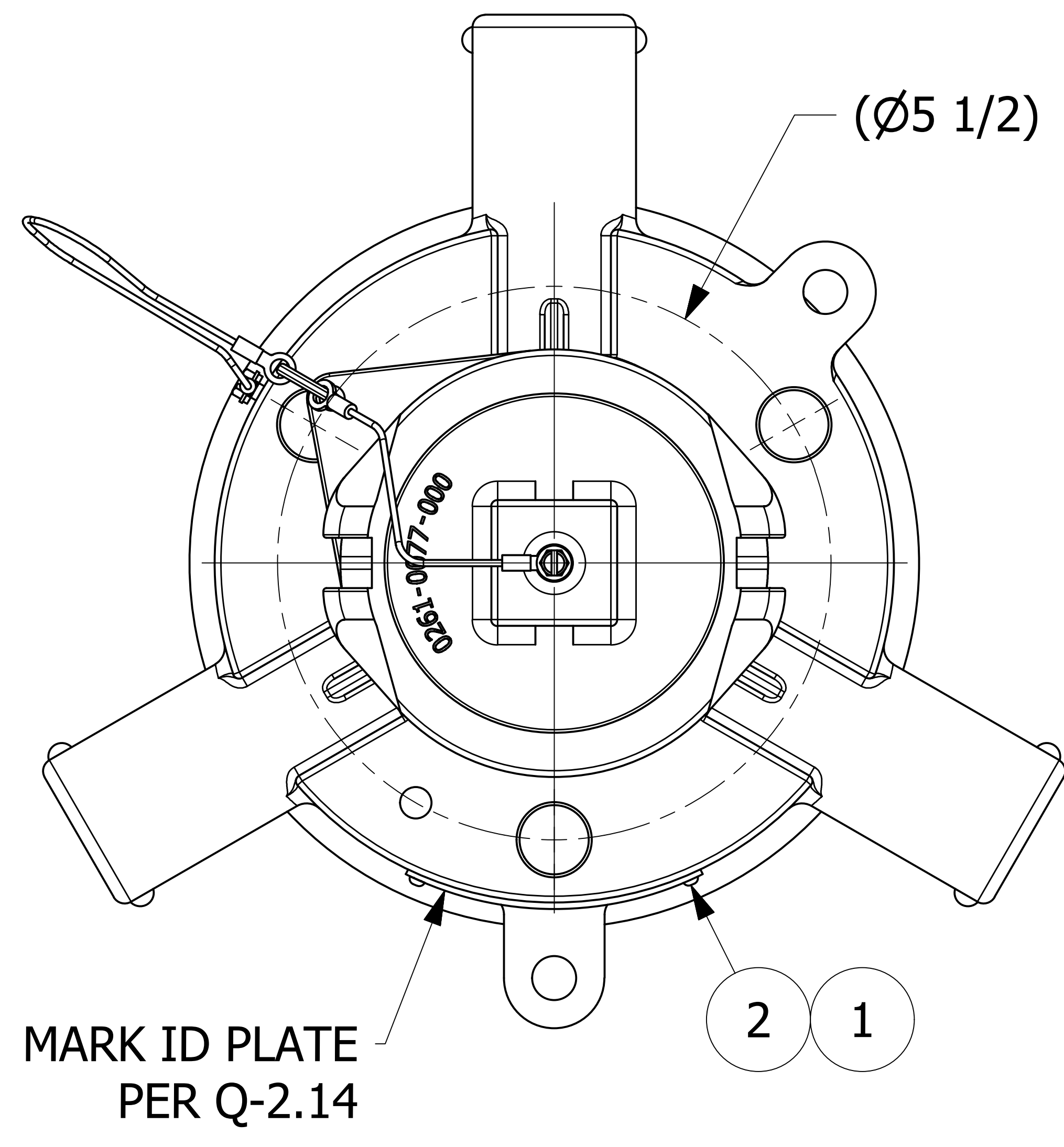

- NOTES:**
1. CUSTOMERS RESPONSIBILITY FOR COMPATIBILITY OF COMMODITY.
  2. AAR APPROVAL # PRD-162102.
  3. SEE DOCUMENT Q-2.14 FOR MARKING PROCEDURE.
  4. FASTEN ID PLATE WITH DRIVE SCREWS.

M	WEB	1/25/22	Q-2.14 WAS QAP5A-1; UPDATED TITLE BLOCK
L	JG	1/10/17	AAR APPROVAL # WAS SRD-063000
K	TAK	9/16/13	ADDED A15152, DR218 & QAP5A-1 NOTE
J	AJB	12/28/06	CHANGED AAR APPROVAL NO.
I	MRC	8/31/00	DRAWING WAS A CHART, UPDATED TO CURRENT STANDARDS DRAWING NUMBER WAS E8565
REV	BY	DATE	DESCRIPTION

UNLESS OTHERWISE SPECIFIED DIMENSIONAL TOLERANCES	DRAWN BY:	CLH
FRACTIONAL: ±1/16	CHECKED BY:	ACC
X.XX: ±.03	PROTOTYPE DATE:	2/9/1998
X.XXX: ±.015	APPROVED FOR PRODUCTION BY:	CLH
ANGULAR: ±1°	PRODUCTION DATE:	2/9/1998
DEBURR ALL SHARP EDGES. ALL MACHINED SURFACES TO HAVE A 125 RMS FINISH UNLESS NOTED OTHERWISE.	SIZE:	E
THIRD ANGLE PROJECTION	DRAWING #:	14941

**SALCO PRODUCTS, INC.**

**QUICK INSPECT SAFETY VENT**

**SEE BOM**

PROJECT #: \_\_\_\_\_ SHEET #: **1 OF 1** SCALE: **1 : 1**

PART #: **QI261NSPR6A**