

NO	PART NAME	PART#	REQ'D	MATERIAL
1	ID PLATE 3" X 3/4"	A15152	.5	ALUMINUM
2	DRIVE SCREW TYPE U #2 X 1/8"	DR218	2	18-8 SS
3	QUICK INSPECT FLANGE GASKET	FG55064	1	GARLOCK 3300
4	QUICK INSPECT SAFETY VENT	QI261BSA	1	BLACK NORYL
5	QI RETAINER GASKET	QI261DG64	1	GARLOCK 3300
6	RUPTURE DISC (SOLD SEPARATELY)			

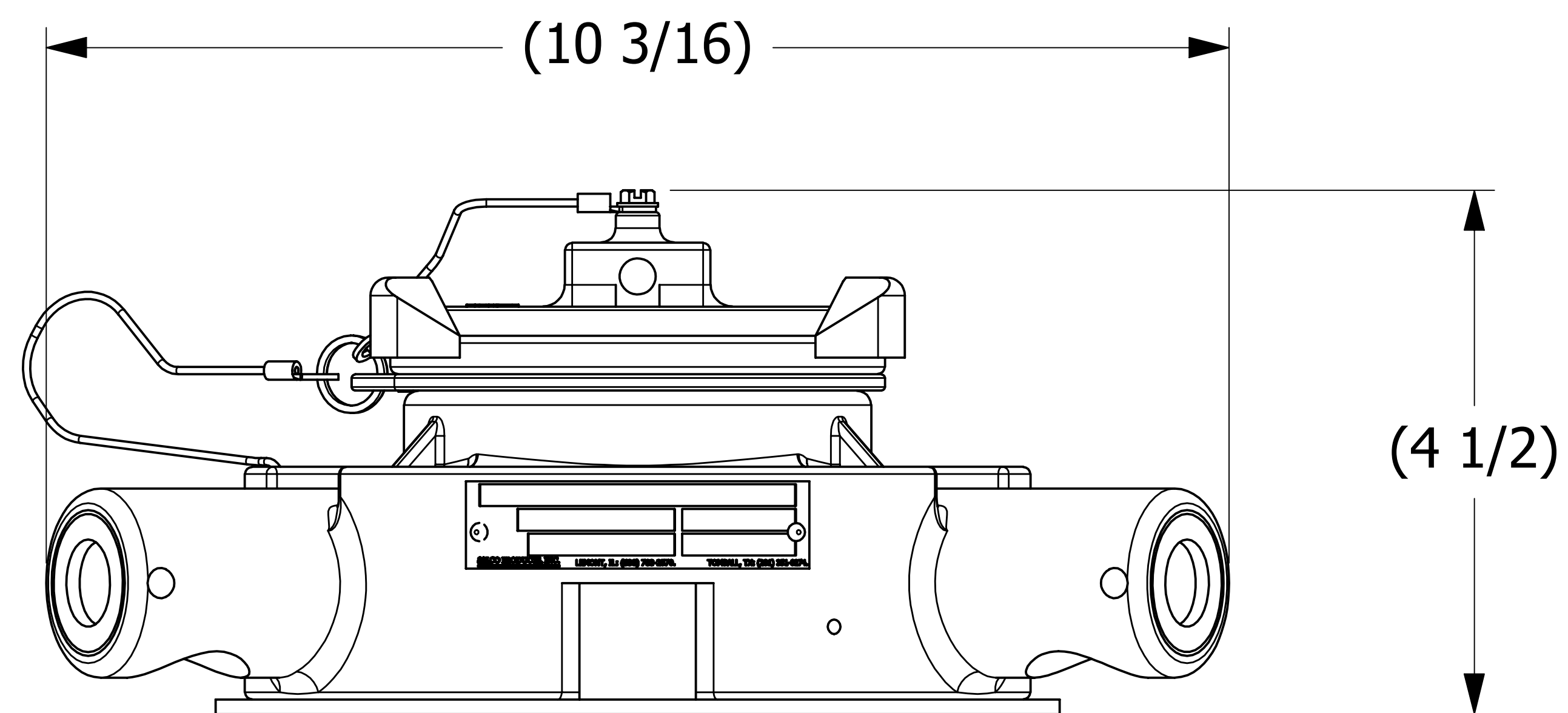
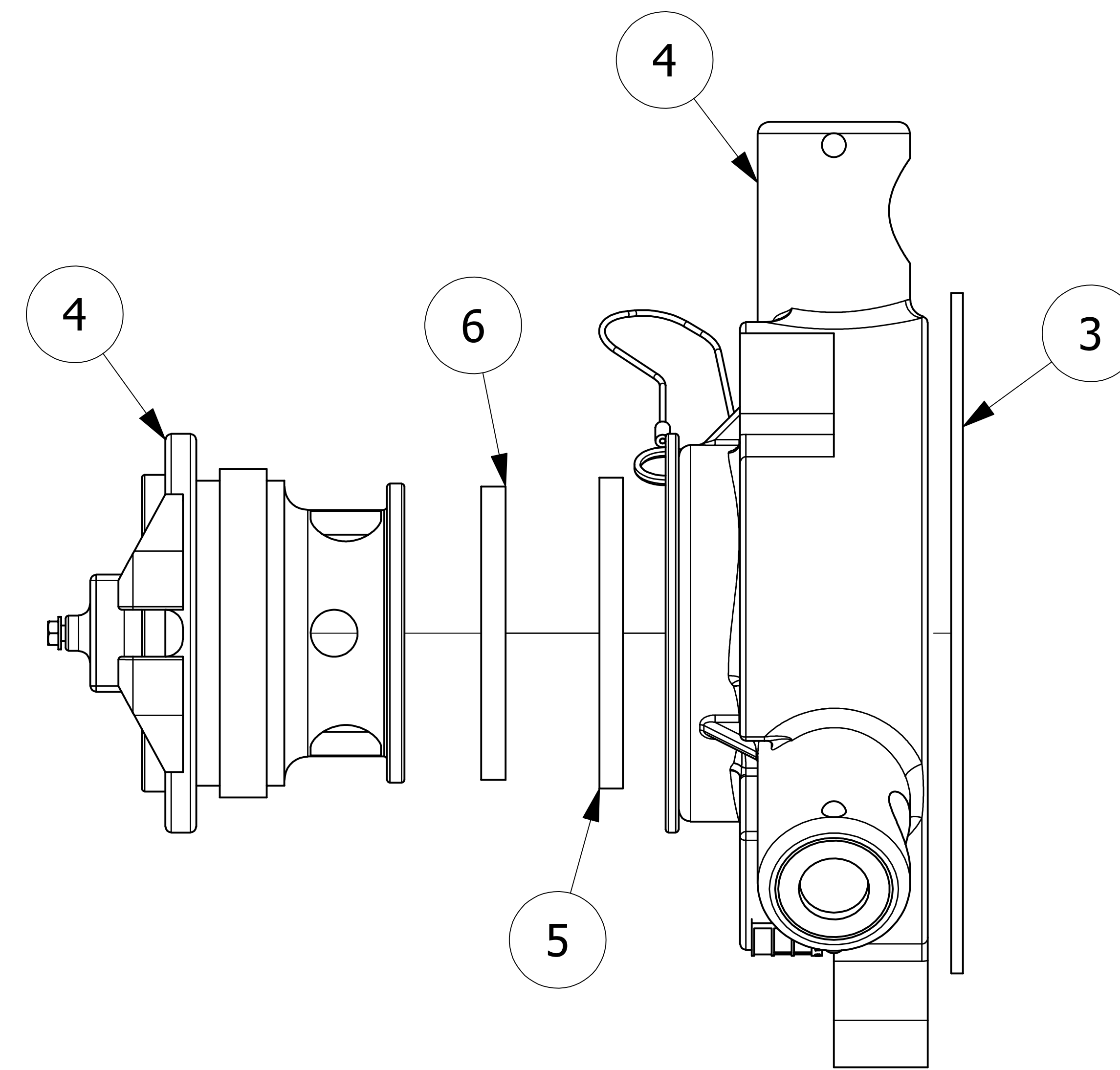
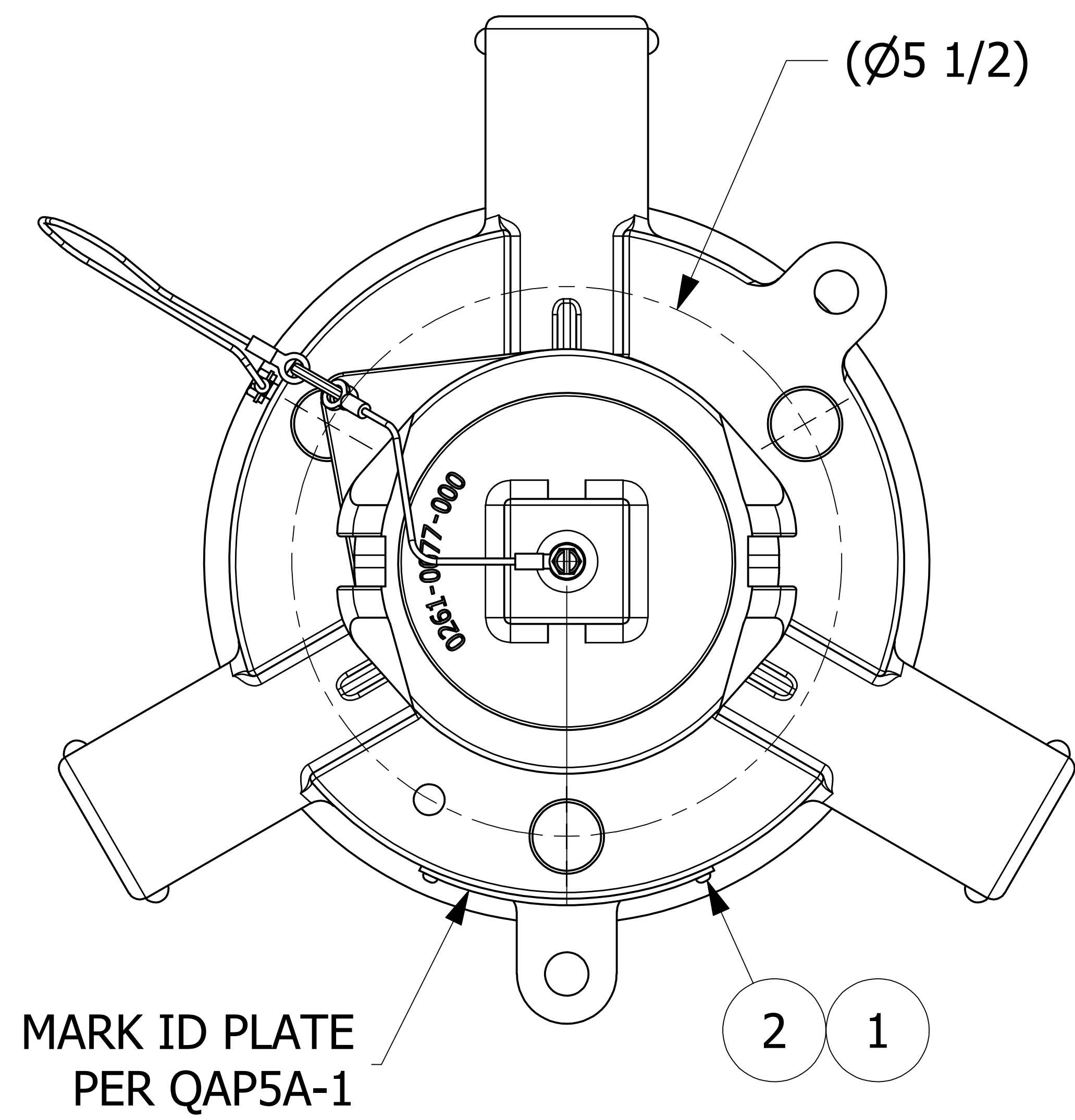

NOTES:

1. CUSTOMERS RESPONSIBILITY FOR COMPATIBILITY OF COMMODITY.
2. AAR APPROVAL # PRD-162102.
3. SEE DOCUMENT QAP5A-1 FOR MARKING PROCEDURE.
4. FASTEN ID PLATE WITH DRIVE SCREWS.

C	JG	2-8-17	AAR APPROVAL # WAS SRD-063000
B	TAK	9-3-13	ADDED A15152, DR218 & QAP5A-1 NOTE
A	CHL	8-18-09	NEW PART ADDED TO SYSTEM
REV	BY	DATE	DESCRIPTION

UNLESS OTHERWISE SPECIFIED DIMENSIONAL TOLERANCES FRACTIONAL: ±1/16 X.XX: ±.03 X.XXX: ±.015 ANGULAR: ±1° DEBURR ALL SHARP EDGES. ALL MACHINED SURFACES TO HAVE A 125 RMS FINISH UNLESS NOTED OTHERWISE. THIRD ANGLE PROJECTION	DRAWN BY:	CHL
	CHECKED BY:	VD
	PROTOTYPE BY:	CHL
	PROTOTYPE DATE:	7/21/2009
	APPROVED FOR PRODUCTION BY:	VD
	PRODUCTION DATE:	8/18/2009

SALCO PRODUCTS, INC.

QUICK INSPECT SAFETY VENT

SEE BOM

PROJECT #: WAG0714 SHEET #: 1 OF 1 SCALE: 1:1

DRAWING #: E27226 PART #: QI261DG64A